

# Studying of 100 KW Micro Wind Farm for Low Wind Speed Machines

W. Roynarin

**Abstract**— Wind machine has become more important to the renewable energy section. However, the wind speed is the major factor to the wind machine power plant. The kinetic energy from the wind converts to electrical energy by the wind machine. The efficient of a good wind machine is about 35 percent. Additionally, the feasible plant factor of wind machine or wind farm could not be lower than 0.2. The higher efficiency of wind machine will shorter pay back period of the power plant investment. However, if the high wind machine designed using in the low wind speed zones, the plant factor is lower than 0.1. Therefore there is not feasible for the investment. Because the most megawatt wind machine is designed for high wind speed area. Thailand and some areas around the world is not suitable for high wind machine design, therefore this paper is presented new concept design and implementation of low wind speed machine integration into micro wind farm by using 20 units of 5 kw low speed wind turbine to 100 kw grid connect system. This 5 kW wind machine is designed for cut in wind speed of 2 m/s and generates electricity of 5000 watts at wind speed of 9 m/s. The designing of micro wind farm configuration and results is presented in this study. Consequence in after 3 months of plant installation, the results showing that the small wind machine wind farm shown the significant plant factor of about 0.22, that higher than a single unit of 100 kW high wind speed wind machine. This project was located at King's farm project in the rural area of Thayang, Petchaburi Province in the Southern of Thailand. The investigation and study is still carrying on for further development of low wind wind machines.

**Keywords**— Wind machine, Micro wind farm, Low speed wind turbine

## 1. INTRODUCTION

Most wind farm nowadays was constructed from a megawatt size wind machine. Megawatt wind turbine requires medium to high wind speed resource. However in some areas the wind speed are lower than the designed wind speed for megawatt wind farm. Additionally, the development of low wind speed turbine has the limitation on the megawatt size. However, the low wind speed turbine is kilowatt model which could be used to implement the mini wind farm in the low wind resource such as Thailand. Therefore, in this study is the investigation and analysis of mini wind farm in low wind speed zone that constructed from a small 5 KW wind machine designed for low wind speed. The most potential of small wind turbine including; low maintenance, easy to installation process, low cost of transportation which may not possible to use the megawatt wind machine were studied in this paper. The concept of small wind machine constructed to mini wind farm therefore may solve the problems of low wind speed areas. The project was shown high performance and efficiency for low wind resource. Additionally, this model may be using for the prototype of using wind machine in low wind speed resource zones.

In this study the small 5 kW wind machine that was designed for cut in and rated for low wind speed zone was using for mini wind farm project. The parameters studies and factors that would be affected to the design process of 5 kW wind machine including:

- The cord length ratio

- Reynolds's number
- Number of blade
- Shape of the airfoils
- Specification of permanent magnet
- Solidity of the wind turbine blades
- Weight per power output ratio of the wind turbine rotor
- Length of wind turbine blade etc.

The above parameters are to be minimum factor that would effect to the power curve of the wind machine.

## 2. THEORY OF LOW WIND SPEED TURBINE DESIGNED CONCEPT

Because the wind speed of the wind class III is too low and we could not control the speed of the wind, therefore low speed wind machine need to concern about the high power output at low wind speed. Unfortunately, increasing the length of turbine blade will reduce the speed of the rotor rotational. Additionally it's would not possible to modify the original wind machine that design for high wind by replacing the longer blade. And also from the study we don't think any change of alternator is going to give high wind machine the wattage we're trying for. The only thing that can think of increasing output is increasing input. Since we can't increase the wind's speed, therefore we suppose this will mean increasing the size of your airfoil blades. Catching more wind at the same speed will increase the energy that is being input into the low wind speed system. At eventually the 5 kW wind machine that was using for constructed of 20 units mini wind farm for low wind speed zone specifications are in as the following:

*Wind Turbine Specifications*

Rotor Diameter: 6.4 meter

Cut in wind speed: 2.5 m/s

Rated wind speed: 9 m/s

Cut out wind speed: 15 m/s

Working rpm: 100- 250 rpm  
 Weight of Nacelle: 150 kg  
 Blade material: Fibre glass Rein forced  
 Sound level at 50 m distance: <30 DB

### 3. AIR-FOIL AND BLADE DESIGN

In the design process of low speed wind machine, the airfoil profile is the most important factor to be concerned. And as we know that for wind turbine engineering, the most important parameters influencing to the efficiency of the wind machine is the shape of the wind turbine.

The airfoil characteristics is the performance of generates lift and drag coefficients  $C_l$  and  $C_d$ . The lift and drag force is generated when the wind passes through an airfoil cross section. When the wind flow passes through the different areas or shapes, the velocity is also altered. It passes more rapidly over the longer (upper) side of the airfoil (see Fig.1), creating a lower- pressure area above the airfoil. From the pressure difference resulting in a force called aerodynamic lift –the drag force is always perpendicular to the lift force.

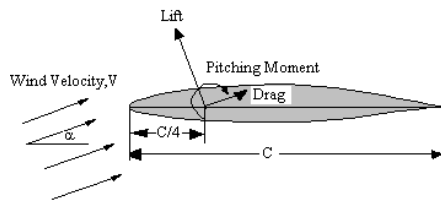

Fig.1 Lift and drag forces when the fluid passes through the airfoil section [1].

In the wind turbine design process, we have to maintain high performance in low wind speed, a higher value of lift and drag ratio is needed and requires a longer period of angle of wind attack  $\alpha$ . The higher the lift to drag ratio is, the more efficient the airfoil. Good airfoil is capable of producing high lift at a small drag penalty. The lift and drag coefficients can be found using equations:

$$C_l = \frac{2L}{\rho V^2 A} \quad C_d = \frac{2D}{\rho V^2 A}$$

Where  $L$  and  $D$  represent the lift and drag force (N) respectively.  $A$  is the cross section area of selected airfoil area ( $m^2$ ),  $V$  is coming wind velocity (m/sec) and  $\rho$  represents the density of the air ( $kg/m^3$ ). The airfoil characteristics will affect the wind turbine rotor performances and suitable for design wind turbine characteristics. The theory of wing sections has been well researched and studied [1-2], and various airfoil sections suitable for low speed wind machine have also been investigated and studied. Most published studies on airfoils characteristics presented today are usually obtained from tests in wind tunnels. The usual tests are carried out over a range of Reynolds number ( $Re$ ), depending on the goal of the study. The  $Re$  may range from 3 to 9 million and at Mach numbers less than 0.17 [1]. In this study, the selected airfoil section for low wind speed has been investigated using special airfoil design for low Reynolds number used. In the test of low speed, the machine was designed with the purposed of maximum power coefficient,  $C_p$  0.35 is recommended. And

concerning about drive train efficiency,  $\eta_d$  and the generator efficiency,  $\eta_g$  then the power output of the wind machine becomes:

$$P_{out} = \frac{1}{2} \rho A C_p \eta_d \eta_g V_0^3 \quad (1)$$

In order to find the rotor swept area,  $A$  would come from the relation

$$A = \frac{2 P_{out}}{(\rho C_p \eta_d \eta_g V_0^3)} \quad (2)$$

This wind turbine is generates power of 5 kW with the mechanical furling system for the storm protection governing the rotor over speed situation. In the design concept the rotor sizing of wind rotor to generate 5 kW in operating area of designed wind rated at 10 m/s. Assuming that a drive train efficiency of 0.8, rotor power coefficient of 0.35 and generator efficiency of 0.85. Therefore, calculates the air density at altitude 30 m above sea level for the reference at the site selection.

$$\rho = 1.255 \exp[(-0.297)(30)/3048] \sim 1.20 kg/m^3$$

Then, calculate the swept rotor area,  $A$  from

$$A = 2(5000) / [(1.20)(0.35)(0.8)(0.85)(10^3)]$$

At the required swept area of  $A = 34.7 m^2$  therefore from  $A = \pi r^2$ ;  $r \sim 3.5m$ . Thus, the rotor diameter of this low speed wind machine at rated at 10 m/s wind velocity would have the rotor diameter of 7 m using in this mini wind farm.

### 4. DESIGN CONFIGURATION

This mini wind farm was design to connected the main utility of 22 kV power supply from PEA. Therefore, three phases stepping up transformer from 380 volts AC to 22 kV ac of the peak of 175 kW was used and installed in this system. In the design, each unit of 5 KW wind turbine is connected to the single phase and divided the 20 units in to three groups, consequently in the connection of three phase utility. In phase R Y B consist of 7 7 and 6 wind machine respectively. For one set of wind turbine unit consist of the main components such as Wind turbine nacelle, wind turbine control system, over load protection box, dummy load of 7.5 kw heat, the grid connect box of single phases, main circuit breaker unit, the monitoring system. The design configurations show in the figures 2.

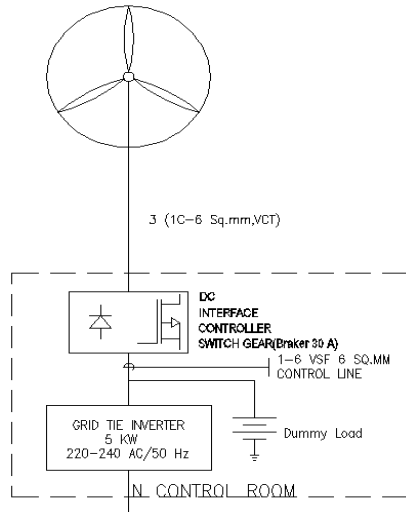

Fig.2 One Unit of 5 KW wind turbine system configuration

The main component describes in Figure 3 have the different in the function to operate in the mini wind farm.

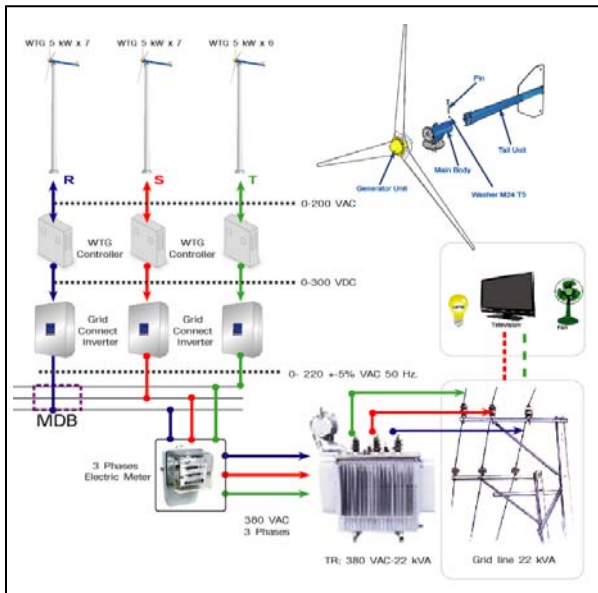

Fig. 3 schematic diagram of 100 Kw mini wind farm located in Thayang, Pecthaburi Thailand

**Wind Turbine Controller (WTC)**

This is using for controlling the status of the wind machine in the operation state. Additionally, it using to protect the system from any abnormal working conditions such as, higher or lower voltage from the utility, grid cut off, higher speed of the rotor, surge from the utility etc.

**Grid connect inverter**

Using for optimum feeding power to the grid with optimum power tracking system. The grid connect inverter is using for the maximum power input from the wind machine of 6 kW and the maximum power output feed to grid line of 5.5 kw. In this project, the system was used the frequency of 50 Hz, with plus and minus 10% errors of the standard to PEA regulations in order to control the quality of the electricity from any poor figures.

**Protection system**

The wind machine system is covering with the maximum protection from the unstable of utility and also the over

speed of wind turbine rotor, which especially can damaged other parts from the centrifugal force at under no load condition. The generator was protected from current limit unit to protect over heat condition when the machine working under high speed and storm condition and gust wind. After 2 months of installation, the 20 units of 5 kW low speed wind machine was generates power to the PEA grid as shown in the Fig.4



Fig.4 100 kW mini-wind farm for grid connect

**5. RESULTS AND DISCUSSION**

The power output of each wind turbine was recorded with data logger and also the wind speed and some factors of the environment were studied in this project. The data of each wind machine was using to plot the power curve of wind speed and power out put of this 5 kW wind machine and show that wind machine is cut in at wind speed of 2.5 m/s and generates 5 kW power output at 9.5 m/s. The average energy production per wind turbine per day is 7 KW/hr that shows about 10 percent of power factor. However, because the wind speed in this site was average about 4 m/s. The machine therefore generates of only about 750 watts/hours average compares to the technical specification of 5 kW wind machine. Additionally, after five months recorded, the energy that generates from this mini-wind farm was shown in Table1.

Table1. Energy production from 100 kW mini wind farm located at King’s Farm, Pecthaburi

End of Month	Wind turbine group phase R	Wind turbine group phase Y	Wind turbine Group Phase B
December 2009	1050 kw/hr	1053 kw/hr	1041 kw/hr
January 2010	1038 kw/hr	1037 kw/hr	1029 kw/hr
February 2010	1032 kw/hr	1048 kw/hr	1025 kw/hr
March 2010	1028 kw/hr	1021 kw/hr	1016 kw/hr
April 2010	1022 kw/hr	1025 kw/hr	1019 kw/hr

From the studied, this mini-wind farm produces about 3100 kw/hr per months. Therefore, the plant factor of this mini-wind farm was not ready to generate and show the result because of the period of recorded time not complete in a whole year yet. However, the new concept of using low speed wind machine in the group turbine could be better using 100 kW high speed wind machine. However, the maintenance in the long term of more number of wind machines may higher than a single unit.

#### **4. ACKNOWLEDGEMENT**

The author would like to acknowledge with the most respective to his majesty the King RAMA 9 for supporting throughout this project. Thank you to RMUTT and team work for very good help and support, I am the most appreciated.

#### **5. REFERENCES**

- [1] F. S. David, M. Eggleston (1985). Wind Turbine Engineering Design New York, Van Nostrand.
- [2] W.Roynarin (2008). A Comparison of High and Low Speed Wind Machine the 6<sup>th</sup> Eco-Energy and Materials Science and Engineering Symposium (6<sup>th</sup> EMSES) Kyoto, Japan.