

# Novel Method to Control Temperature on Aluminum Side Using Customized Proportional Controller Based on Disturbance Observer

Sarayut Yaemprayoon, Chowarit Mitsuntisuk, Kiyoshi Ohishi, and Jakkree Srinoncha

**Abstract**—This paper proposes the novel method to control temperature on the aluminum side by using customized proportional controller. Moreover, the system is applied disturbance observer to estimate heat disturbance, and compensate it. In the equipment part, the thermoelectric module is used Peltier device. This device is a type suitable for analysis thermal system, because the device has a fast response and high stability. Also this proposal used high speed FPGA controller for the programming and signal processing. The result of this research can be guideline to analysis thermal systems on the aluminum side for various applications.

**Index Terms**—Customization proportional controller (CP controller), proportional–integral–derivative controller (PID controller), temperature control, heat disturbance and disturbance observer.

## I. INTRODUCTION

Many researches focus on the transmission force from human to robot or object [1], [2]. However, only the force is insufficient for the complete Haptic sensation. In order to the human Haptic have force and temperature sensation. Therefore, this research is proposed development the temperature controller. The proposal method is used customization proportional controller (CP controller) and applying disturbance observer (DOB). This method can obtained more robust system. Therefore, the information is explained in this paper, and the validity can be confirmed by experimental results.

The temperature controlling has various methods such as a fuzzy logic with Proportional–Integral–Derivative (PID) controller [3], which this controller works well. However, the response of the PID controller is slower and more complicate than P controller. Generally, the P controller is able to obtain a good tracking of a reference point. However, the result of this controller is an overshoot. For this reason, this research proposes developing temperature control by using CP controller. This method can be reduced the overshoot of the system by using the characteristic of the Peltier device [4]. Moreover, It can notice the importance of combination between disturbance observer and CP controller, because the research is applied P controller with this method as explanation in [5]. The result of this system can obtain more than the robust controller.

The disturbance observer is mainly used in the field of

motion control [6] and can estimate the amount of force disturbance by comparing the output of the system with nominal value of input. In the temperature control, disturbance of the system is named a heat disturbance, and using the structure of disturbance observer. Therefore, this paper, heat disturbance observer is named HDOB. By the proposed system, the effect of the heat disturbance is compensated conversion for the current source. The disturbance observer is simple to design and easy to implement. Moreover, the heat sensor has a limited bandwidth, and need to set up in the object, whilst heat value can be estimated with the disturbance observer. In addition, the heat sensor has a lot of noise, while disturbance observer with programming low pass filter can reduce them.

In the equipment part, the thermoelectric module is used Peltier device. This device is a suitable type for analysis thermal system, because it has a relatively fast response among thermal devices [7]. It is used in many applications, such as a small refrigerator or CPU coolers. The device using only a DC power source is easy to drive, and it can change cool side or hot side by reversing direction of the current source. In the experiment setup, the top of the Peltier side is arranged the aluminum sheet, because it is the same include loader and analysis temperature control with material [8], [9]. Moreover, some object of the temperature control need to contact with the material. In the controller unit part, this research is used high speed FPGA. It is suitable for the temperature control and combination with force for the complete Haptic sensation in the future. The FPGA controls Peltier by using H-bridge to put current and to revert direction. The temperature value is measure by using digital sensor with range from  $-55^{\circ}\text{C}$  to  $+125^{\circ}\text{C}$ . As a result, the temperature control becomes more robust to those disturbances consequently, because the system is only used digital. It is easy to programming with FPGA and protection noise working well.

The contents of this paper will be written as follows. The equivalent circuit of the thermal system is given in the section II. Using equation is analyzed from equivalent circuit. Meanwhile, the proposed method CP controller with disturbance observer is explained in section III. The validity of proposal method is confirmed by experimental results in section IV. The last section is conclusion of this research.

## II. EQUIVALENT CIRCUIT AND MODELING SYSTEM DESCRIPTION

The equations of the temperature control in this research are analyzed from the equivalent circuit as shown in Fig. 1. It is applied from another research as shown in [10]. The

Manuscript received January 25, 2012; revised February 30, 2012.

The authors are with the Department of Electronic and Telecommunication, Rajamangala University of Technology Thanyaburi, Thailand (Sarayut\_Yaemprayoon@hotmail.com; chowarit@stn.nagaokaut.ac.jp; ohishi@vos.nagaokaut.ac.jp; Jakkree.s@en.mutt.ac.th)



equivalent circuit consists of Peltier device, aluminum sheet and objects. The objects are contact with aluminum side such as human's finger or materials. This is factor heat disturbance into system, and it is can compensate with disturbance observer. The aluminum sheet is connected to the hot side node, because the experiment in this research focused on the hot temperature control. The cool side is the same. It is depended on the application. The definitions of the equivalent circuit and equation are used in this research given in the Table I.

R	Thermal Resistance (K/W)
$R_e$	Electronic Resistance ( $\Omega$ )
$\omega_{dis}$	Cutoff frequency (rad/s)
U	Voltage (V)
I	Current source (A)
$\alpha$	Seebeck coefficient of Peltier device (V/K)
s	Laplace operator
$K_{pst}$	Proportional gain start point
$K_{psp}$	Proportional gain stop point
Subscripts: c	Cool side
Subscripts: h	Hot side
Subscripts: p	Peltier device
Subscripts: a	Aluminum Plant
Subscripts: o	Output
Subscripts: n	Nominal value
Subscripts: cmd	Command
Subscripts: cms	Compensate
Subscripts: dis	Disturbance
Superscripts: ^	Estimation value

TABLE I. LISTS OF VARIABLE AND SUBSCRIPTS DEFINITION

Parameter	Value
T	Temperature ( $^{\circ}\text{C}$ )
q	Heat flow (W)
$q_k$	Heat physical constant (W)
$q_{pa}$	Heat connection between Peltier device and aluminum
$q_j/2$	Joule Heat in Peltier device (W)
C	Thermal Capacitance (J/K)

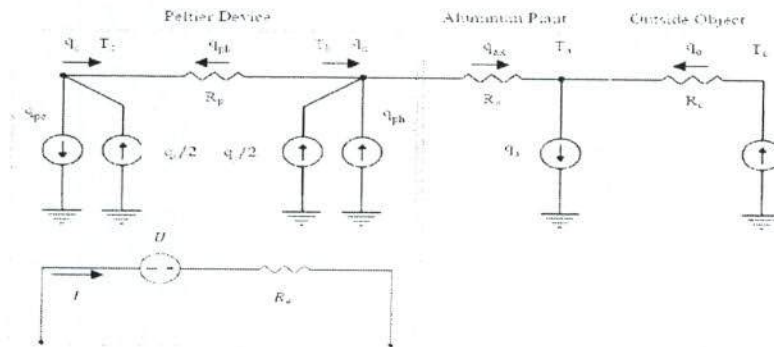
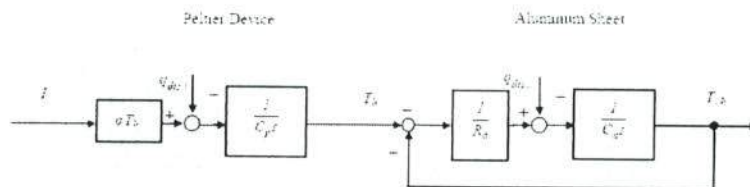
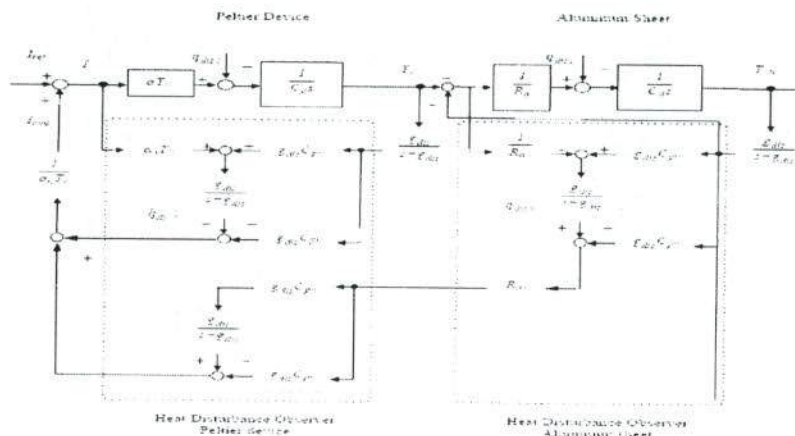

Fig 1 Modeling of the thermal system in this research



(a) Temperature control by peltier device on the aluminum sheet



(b) Temperature control by Peltier device on the aluminum sheet with HDOB.  
Fig. 2. Block diagram of the temperature control on the aluminum sheet (Open loop).

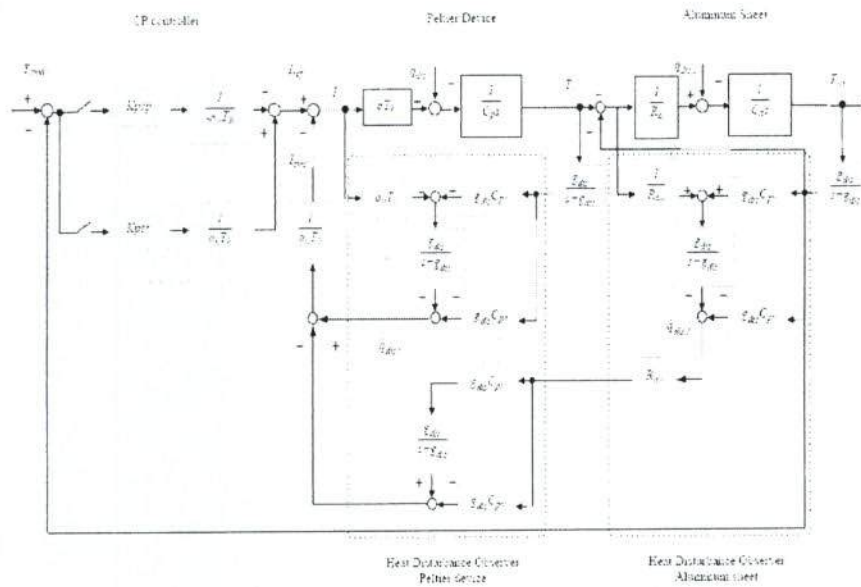

Fig. 3. Block diagram of the temperature control on the aluminum sheet (close loop).

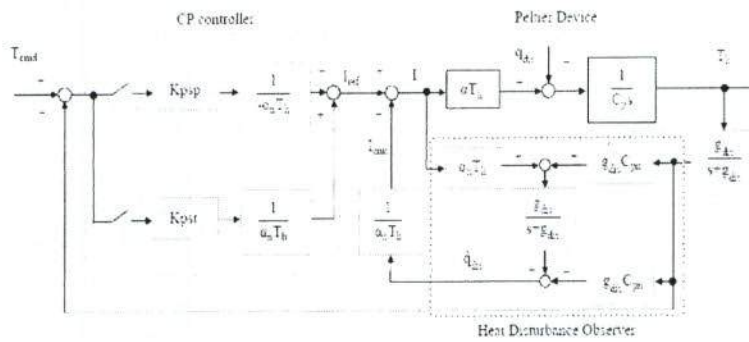

Fig. 4. Block diagram of the temperature control (improvement).

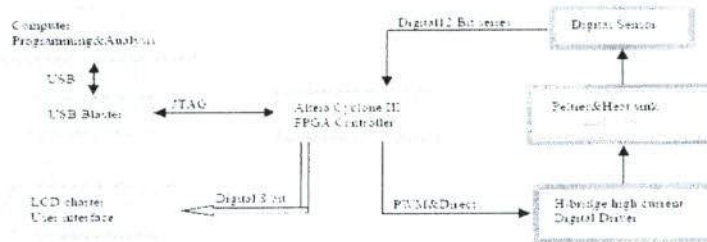

Fig. 5. Schematic block diagram control.

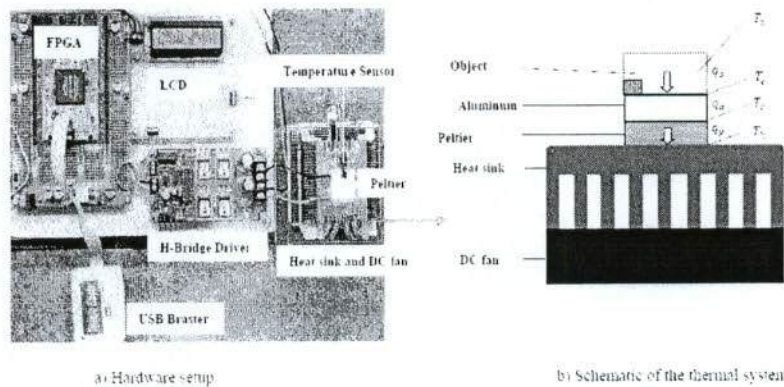

Fig. 6. Experiment setup



In the Fig. 1, hot side node of the Peltier device can analyze to

$$q_h = q_{ph} + \frac{q_j}{2} - q_{pk} - q_{ak} \quad (1)$$

Therefore, the device reverts to cool side. The equation becomes

$$q_c = -q_{pc} + \frac{q_j}{2} + q_{pk} + q_{ak} \quad (2)$$

On the aluminum sheet, the equation can analyze to

$$q_a = q_{ak} - q_o \quad (3)$$

The thermoelectric modules have a basic equation of the heat. The equation using in this research is

$$q = IU = I^2 R = \frac{T_{different}}{R} \quad (4)$$

Moreover, the seedback coefficient (5) of the Peltier is measure from applying maximum voltage to the device per temperature changing. Analysis to the equation becomes

$$\alpha = \frac{U_{max}}{T_{hmax}} \quad (5)$$

From equation (4) and (5) instead of equation (1) to

$$q_h = \alpha T_o I + \frac{I^2 R_e}{2} - \frac{T_h - T_c}{R_p} - \frac{T_a - T_h}{R_a} \quad (6)$$

In addition, the heat equations explained above. It can analyze from the thermal capacitance in terms of temperature/time derivative. It can be explained to the equation (7). This equation is applied from another research as shown in [11].

$$C \frac{dT}{dt} = q \quad (7)$$

The equation of the temperature control in is explained in next equation.

$$C_p \frac{dT_h}{dt} = \alpha T_h I + \frac{I^2 R_e}{2} - \frac{T_h - T_c}{R_p} - \frac{T_a - T_h}{R_a} \quad (8)$$

$$C_a \frac{dT_a}{dt} = \frac{T_a - T_h}{R_a} - q_o \quad (9)$$

From the equation (8),  $C_p \frac{dT_h}{dt}$  is output of the Peltier device, and  $\alpha T_h I$  is actual value of the control system or control Peltier device part. In the disturbance section,  $\frac{I^2 R_e}{2} - \frac{T_h - T_c}{R_p}$  are heat disturbance in the Peltier device. In the equation (9), it is aluminum sheet section. Also  $C_a \frac{dT_a}{dt}$  is output of the aluminum sheet or output of the system,  $\frac{T_a - T_h}{R_a}$  is heat physical constant of the aluminum sheet. Therefore,  $q_o$  is output heat disturbance into system. Moreover, installation between Peltier and aluminum is a kind of thermal resistance. It is kind of the heat disturbance ( $q_{pd}$ ). All of the disturbance value can be designed to compensate with structure of the

disturbance observer. Therefore, the equation (8) and (9) become to block diagram Fig. 2 (a), and HDOB with low pass filter as shown in the Fig. 2 (b), and the final block diagram and proposal method is explained in the next section.

### III. CONTROLLER DESIGN

To design the temperature control, the block diagram is shown in Fig. 3. It consists of actual control (block black line) and nominal value or programming with FPGA (block blue line). In the block diagram, the nominal value is also 2 parts the CP controller and disturbance observer. It is propose method in this research.

In the Fig. 3, the frame of the Peltier device is converted from equation (8) to block diagram. Therefore, heats disturb into system as shown in the next equation.

$$q_{dis1} = \frac{I^2 R_e}{2} - \frac{T_h - T_c}{R_p} \quad (10)$$

Moreover, the frame of the aluminum sheet is converted from equation (8) to block diagram also. Therefore, heats disturbance is

$$q_{dis2} = q_o + q_r \quad (11)$$

The heat disturbance are the problem to control the thermal system, but it can be estimated and compensated by the structure of the disturbance observer. The estimation method is compared the output of the system with nominal value of input. The heat nominal input of the Peltier device is applied from equation (3) and (4). It becomes to

$$q_{ref} = I \alpha T_o \quad (12)$$

Nominal value input of the aluminum sheet is applied from

$$q_a = \frac{T_a - T_h}{R_a} \quad (13)$$

The nominal output is obtained from equation (8) and (9). Moreover, the system is used low pass filter (LPF) to reduce noise in the section of heat disturbance observer and digital temperature sensor. The transfer function of the filter is shown as

$$G(S) = \frac{g_{dis}}{s + g_{dis}} \quad (14)$$

The last frame of the block is a CP controller. It uses this method, because the response of the PID controller is slower P controller. Generally, the P controller is able to obtain a good tracking of a reference point. Moreover, the PID controller is also more complicated to design, because the system needs to choose three gain ( $K_p$ ,  $K_i$ ,  $K_d$ ), while P controller is selected the single best gain ( $K_p$ ). However, the result of this controller is an overshoot. For this reason, this research is proposed the development of temperature control by using CP controller. This method can be reduced the overshoot of the system by using the characteristic of the Peltier device.



The H-bridge driver circuit is used to put the current and to reverse the direction current source of the Peltier device. By using the characteristic of this device, it is possible to change to hot or cool status on the surface with the reversing direction of the current (same as a DC motor). By considering of the reference command, from the start point to the 30% of reference are controlled to the hot status.

After the 30% to the peak of the overshoot, the reversing direction of current is changed to control from the hot status to cool status. By using the proposed method, it is possible to reduce the overshoot of the system. It is use 30% to reverse, because from the experimental is the best result.

From block diagram in Fig. 3, it can improve to easy than. The method explains in the next section.

#### IV. IMPROVEMENT CONTROLLER DESIGN

In the Fig.3, this block diagram is difficult to fine thermal resistant of the joint between Peltier device and aluminum sheet, because it depends on the process of the connection. Moreover, it is also difficult to program by FPGA. However, the section of aluminum sheet can see in the kind of the heat disturbance. Therefore, it can use block diagram in the Fig. 4 to control temperature on aluminum side, while HDOB is

$$q_{dis} = \frac{I^2 R_c}{2} - \frac{T_h T_c}{R_p} + q_o + q_{pu} \quad (15)$$

The disturbance observer is applied structure from motion control. The block is shown in the frame of the heat disturbance in the Fig. 4. Motion control is estimated force disturbance, while thermal control system is the heat estimation. Therefore, the heat estimation is described as

$$\hat{q}_{dis} = \frac{a_n T_{on} g_{dis} J - g_{dis} c_p T_o s}{s^2 g_{dis}} \quad (16)$$

From the Fig.4, transfer function of the start point is shown as following

$$\frac{T_h}{T_{cmd}} = \frac{\alpha K_{pt} S^2 + 2\alpha g_{dis} K_{pt} S + \alpha g_{dis}^2 K_{pt}}{A} \quad (17)$$

where:  $A = \alpha_n C_p S^3 + (2\alpha_n C_p g_{dis} - \alpha_n C_p g_{dis}) S^2 + (\alpha_n C_p g_{dis}^2 - \alpha_n C_p g_{dis}^2 - \alpha g_{dis}^2 C_{pn} + \alpha g_{dis} K_{pt}) S + \alpha g_{dis}^2 K_{pt}$

After the 30% to the peak of the overshoot, the transfer function of this point is realized as following

$$\frac{T_h}{T_{cmd}} = \frac{\alpha K_{pp} S^2 + 2\alpha g_{dis} K_{pp} S + \alpha g_{dis}^2 K_{pp}}{B} \quad (18)$$

where:  $B = \alpha_n C_p S^3 + (2\alpha_n C_p g_{dis} - \alpha_n C_p g_{dis}) S^2 + (\alpha_n C_p g_{dis}^2 - \alpha_n C_p g_{dis}^2 - \alpha g_{dis}^2 C_{pn} + \alpha g_{dis} K_{pp}) S + \alpha g_{dis}^2 K_{pp}$

In the section of CP controller, it is changing to the PID controller. The transfer function becomes

$$\frac{T_h}{T_{cmd}} = \frac{C}{D} \quad (19)$$

where:  $C = \alpha K_d s^4 + (\alpha K_p + 2\alpha g_{dis} K_d) s^3 + (2\alpha g_{dis} K_p + \alpha K_i + \alpha g_{dis}^2 K_d) s^2 + (\alpha g_{dis}^2 K_p + 2\alpha g_{dis} K_i) s + \alpha g_{dis}^2 K_i$

where:  $D = \alpha_n C_p s^4 + (2\alpha_n C_p g_{dis} - \alpha_n C_p g_{dis} + \alpha g_{dis} K_d) s^3 + (\alpha_n C_p g_{dis}^2 - \alpha_n C_p g_{dis}^2 - \alpha C_{pn} g_{dis}^2 + \alpha g_{dis} K_p + \alpha g_{dis}^2 K_d) s^2 + (\alpha g_{dis} K_i + \alpha g_{dis}^2 K_p) s + \alpha g_{dis}^2 K_i$

In this method, It can be reduced the overshoot, because the Peltier device still has surface hot after the reference position, while the controller not put the current source. It is a long time to down. In this reason, the method quickly to reverse the surface to cool can be obtained good tacking the reference more than only the P controller. In described above, the experiment is shown in the next section.

The method in Fig.4 is shown in [12], and it can apply to control temperature. This method can be confirmed by experimental result as show in the next section.

#### V. EXPERIMENTS

To confirm the validity of the proposal method, several experiment setup and results are conducted in this section.

##### A. Experimental Setup

The schematic block diagram of the temperature control is shown in Fig. 5. The block diagram consists of:

- Altera Cyclone III FPGA is used EP3C120F780C8N version to control system.
- Computer uses for programming FPGA and analysis signal data. The programming is applied VHDL language with Quartus II software, and using USB blaster connected between computer and FPGA.
- LCD character displays value temperature and referent temperature.
- Peltier device is used version ETC-031-14-11-E. The device is arranged on the heat sink and DC fan to dissipate the endothermic heat flow.
- The H-bridge driver is used to put current and to reverse direction current for Peltier device with mosfet IRF3205 (Maximum 110A). It is control voltage by FPGA with series PWM.
- The digital temperature sensor used DS18B20 version with 12 bit for reading temperature.

The experiment hardware setup is shown in Fig. 6 (a). The main equipments are controller unit, driver current and thermal system. The FPGA controller unit is used high speed with a clock frequency 50 MHz (20ns). The driver can be supplied the current to the device, and it can be reversed direction of the current to hot or cool on the Peltier device. A method to reverse direction current is proposed method in this research.

The last main equipment is a thermal system. The schematic of this system is given in the Fig. 6 (b). The Peltier device is mounted on the heat sink with DC fan to dissipate the endothermic heat flow, and top side of device arranged aluminum sheet. The top of aluminum is arranged digital temperature sensor to measure the temperature value. In the explanation above, the system control is used only the digital. It easy to control by FPGA, because it is not used digital to analog convertor (DAC) or analog to digital convertor (ADC). It is easy to programming, and digital system is protected



noise working well.

**B. Experimental Result**

The proposed control system design is confirmed by experiment. Several experiment results are shown in the Fig. 6. The temperature command is set to difference 8 °C from temperature room. The parameters are used in these experiments given in the Table II.

Firstly, CP controller method is changed the direction of current to reduce the overshoot. In this method, the experimental result comparison between P controller and CP controller is shown in the Fig. 7 (a). The proposal method retains the properties of the P controller. Therefore, it is giving a faster response when comparison with PID controller as shown the Fig. 7 (b). At the time around 200 s, we are used another Peltier to touch the aluminum sheet for testing the outside object disturbance into system. The CP controller has response to tacking better the PID controller.

Secondly, the Fig. 7 (c) is a comparison between using and

not using the disturbance observer. From the experimental results it can be seen that, the robust controller can be obtained by using disturbance observer. The Fig. 7 (d) is experiment when the object disturbance in to system at the time around 200 s. it can be confirmed that the proposed CP controller based on disturbance observer is obtain the better results to reject the disturbance.

TABLE II. PARAMETER USE IN THIS EXPERIMENT

Parameter	Value
$K_{pst}$	1.5
$K_{psp}$	4
$K_p$	0.1
$K_i$	0.15
$K_d$	0.5
$\theta_{dis}$	↑ (rad/s)
$C_p$	0.8 (W/K)
$\alpha$	0.0127 (V/K)

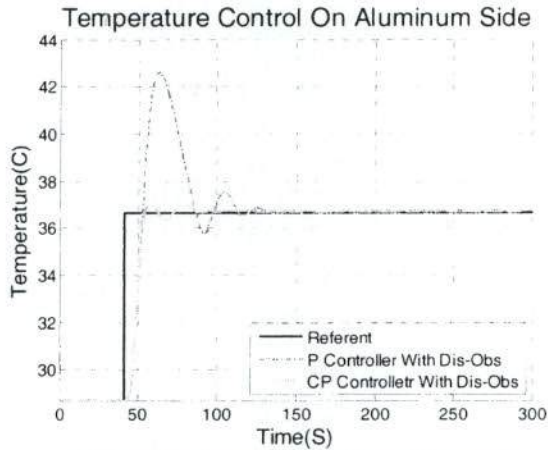

(a) Comparison between P controller and CP controller

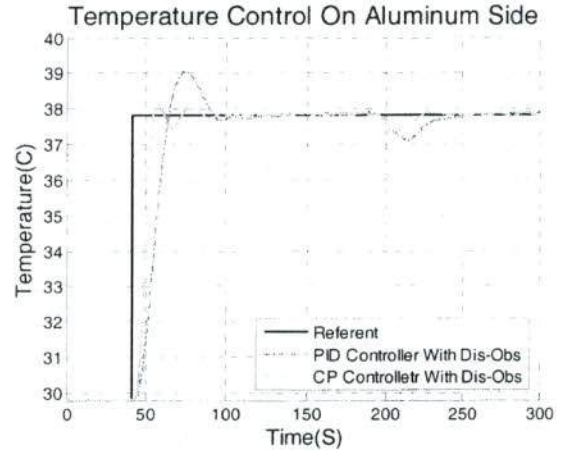

(b) Comparison between PID controller and CP controller

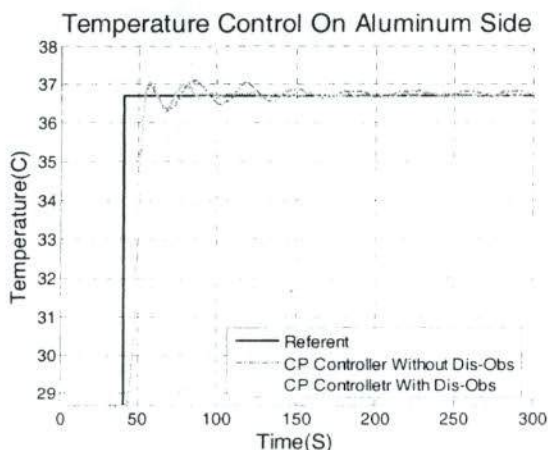

(c) CP controller not using and using DOB

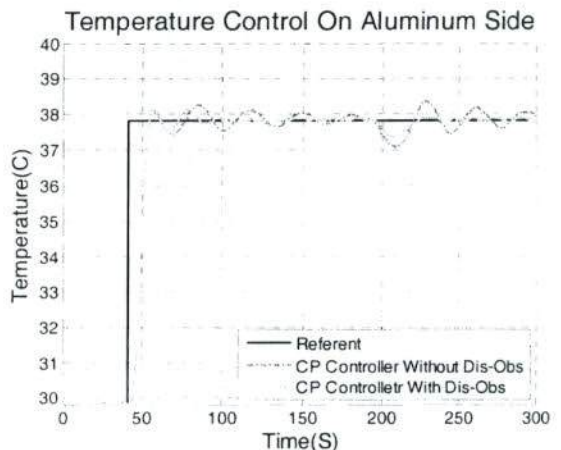

(d) CP controller not using and using DOB (Outside disturbance into system)

Fig. 7. Experiment result.

**VI. CONCLUSION**

From the development of the method to control temperature, the CP controller provides better results than the

PID controller, because it still used characteristic of the P controller, while the customization is a method for reducing the overshoot. Moreover, the system is applied disturbance observer in conjunction with the CP controller. The response



of this method can give the robust system. It can be used to guideline the analysis of temperature control with Peltier device on the aluminum sheet for applications obtaining better stability. In the future research, we will focus on the bilateral temperature controller and combination with force. This system can be applied to complete the Haptic sensation system between human and robot or material.

#### ACKNOWLEDGMENT

This research was supported by Nagaoka University of Technology Japan (Motion Control Laboratory) in conjunction with Rajamangala University of Technology Thanyaburi Thailand (Signal Processing Research Laboratory).

#### REFERENCES

- [1] C. Mitsantisuk, S. Katsura, and K. Ohishi, "Force Control of Human-Robot Interaction Using Twin Direct-Drive Motor System Based on Modal Space Design," *IEEE Transactions on Industrial Electronics*, vol. 57, no. 4, pp.1383-1392, April 2010.
- [2] M. J. Nandayapa Alfaro, C. Mitsantisuk, and K. Ohishi, "Velocity Control Based on a Wide Range of Velocity Estimation in FPGA," *IEEJ/Japan Conference on Industrial Instrumentation and Control*, pp. 89-94, 2011.
- [3] Z.-J. Yan, Y. Xue, J.-H. Ye, H. Qian, and X.-H. Yang, "Main Steam Temperature Composite Control System Based on Variable Universe Fuzzy Logic Control Integrated With Immune And Self-Tuning Pid Controller," in *Proc. of the Eighth International Conference on Machine Learning and Cybernetics, Baoding*, pp.712-716, July 2009.
- [4] S. Lineykin and S. Ben-Yaakov, "PSPICE-Compatible Equivalent Circuit of Thermoelectric Coolers," *Power Electronics Specialists Conference, 2005. PESC '05. IEEE 36th*, pp.608-612, June 2005.
- [5] H. Morimitsu and S. Katsura, "A Method to Control a Peltier Device Based on Heat Disturbance Observer," *IECON 2010 - 36th Annual Conference on IEEE Industrial Electronics Society*, no. 4, pp.1222-1227, November 2007.
- [6] C. Mitsantisuk, K. Ohishi, S. Urushihara, and S. Katsura, "Kalman Filter-Based Disturbance Observer and its Applications to Sensorless Force Control," *Advanced Robotics*, No. 1, pp.335-353, October 2011.
- [7] C. Alaoui, "Peltier Thermoelectric Modules Modeling and Evaluation," *International Journal of Engineering (IJE)*, pp. 114 - 121, April 2011.
- [8] M. Deng, A. Inoue, and Y. Tahara, "Experimental Study on Operator Based Nonlinear Temperature Control of an Aluminum Plate Actuated by a Peltier Device," *SICE Annual Conference 2008*, pp.1405-1408, August 2008.
- [9] M. Deng, A. Inoue, and S. Goto, "Operator Based Thermal Control Of An Aluminumplate With A Peltier Device," *ICIC International*, vol. 4, no. 12, pp. 3219-3229, December 2008.
- [10] S. Lineykin and S. Ben-Yaakov, "Modeling and Analysis of Thermoelectric Modules," *IEEE Transactions On Industry Applications*, vol 43, no. 4, pp.505-512, March-april 2007.
- [11] H. Morimitsu and S. Katsura, "Heat Inflow Control of Peltier Device Based on Heat Inflow Observer," *SICE Annual Conference 2010*, pp. 996-1001, August 2010.
- [12] S. Yaemprayoon, C. Mitsantisuk, K. Ohishi, and J. Srinonchat "Development Control Thermoelectric Technique Using Customized Proportional Controller and Disturbance Observer," *2011 International Conference on Computer and Computational Intelligence*, pp. 996-1001, December 2011.



**Sarayut Yaemprayoon** received the bachelor's degree in electronic and telecommunication engineering from Rajamangala University of Technology Thanyaburi (RMUTT), Thailand, in 1995 where he is currently studying toward the master's degree in the Department of Electrical Engineering, RMUTT also. From 2010 to 2011, He has research student in His research interests include Haptic temperature control by FPGA controller.



**Chowarit Mitsantisuk** received the B.S degree in electrical engineering from Thammasat University, Pathumthani, Thailand, in 2003 and the M.S. degree and Ph.D. degrees in electrical engineering from Nagaoka University of Technology, Nagaoka, Japan, in 2007, and 2004, respectively. From 2010, he was a Postdoctoral in Nagaoka University of Technology by JSPS scholarship. His research interests include motion control, force control,

human-robot interaction, sensor fusion, and real-world haptics. In the 2009, He was IEEE IES student scholarship award and best presentation award.



**Kiyoshi Ohishi** received the B.E., M.E., and Ph.D. degrees in electrical engineering from Keio University, Yokohama, Japan, in 1981, 1983, and 1986, respectively.

From 1986 to 1993, he was an Associate Professor with the Osaka Institute of Technology, Osaka, Japan. Since 1993, he has been with the Department of Electrical Engineering, Nagaoka University of Technology, Nagaoka, Japan, where he became a Professor in 2003. His research interests include power electronics, mechatronics, and motion control.

Dr. Ohishi received the Outstanding Paper Awards at the 1985 IEEE International Conference on Industrial Electronics, Control, and Instrumentation (IECON) and the Best Paper Awards at IECON'02 and IECON'04 from the IEEE Industrial Electronics Society. He also received the Best Paper Award from the Institute of Electrical Engineers of Japan in 2002 and 2009.



**Jakkree Srinonchat** received his undergraduate degree from Rajamangala University of Technology Thanyaburi (RMUTT), Thailand, in 1995, and his Ph.D. in Electrical Engineering, major signal processing from University of Northumbria at Newcastle, UK, in 2005. He awarded the scholarship from Royal Academic of Engineering, UK in 2002, to do the research "stochastic encoding" and also awarded the scholarship from IEEE organization to research "optimization signal codebook" in 2003.

He is currently a lecturer of Department of Electronics and Telecommunication Engineering, Faculty of Engineering, RMUTT, Thailand.

His research on the signal processing, especially FPGA Design, speech and image processing, is published in the proceeding of international conference and journal. He is currently the advisor of the Signal Processing Research Laboratory, which establishes to provide and services the new design and solution to industry.

เอกสารแนบ 2

Date: Wed, 1 Feb 2012 14:22:30 +0800

From: ijiee@vip.163.com

To: sarayut\_yaemprayoon@hotmail.com, jakkree\_s@hotmail.com

Subject: Re:RE: IJIEE Editorial Board---C086

Dear Sarayut Yaemprayoon and Jakkree Srinonchat

Congratulations. Your final paper is accepted, which will be published in the upcoming issue in March. Please check at: <http://www.ijiee.org/content.htm> for updates and the hard copy is for sale at: <http://www.ijiee.org/buy.htm> after online publication. If you have any inquiry, please feel free to contact me.

Best Regards,

IJIEE

<http://www.ijiee.org/>